

Compactor Specifications Model VSP-IV Commercial Vertical Stationary Compactor

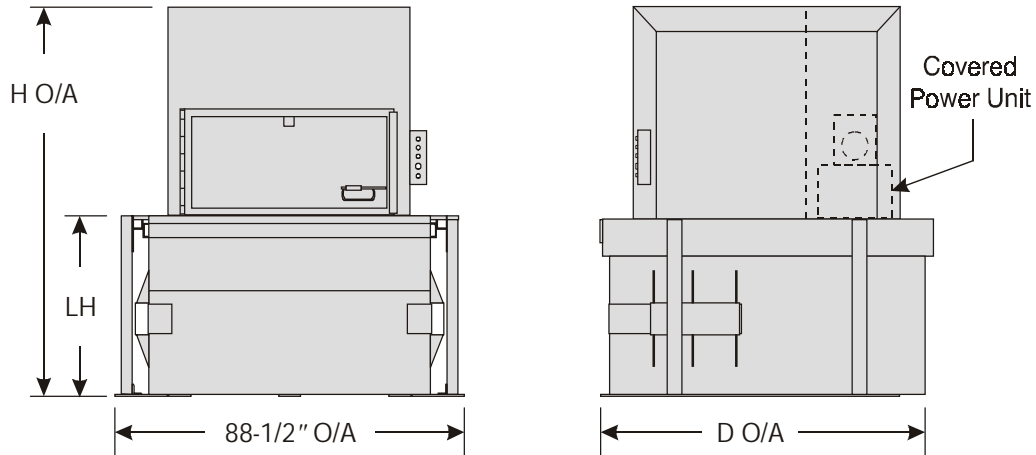

Container Capacity	2	3	4	6	7
LH (Load Height)	43"	33"	42"	60"	69"
H (Overall Height)	104"	93-1/2"	102-1/2"	120-1/2"	129-1/2"
D (Overall Depth)*	49-1/2"	77"	77"	77"	77"
Estimated Weight					
W/ Container Lbs.	5,000	5,450	5,550	5,850	5,950

*Model with a 2 cu. yd. container is supplied with a remote power unit

Standard Features

Frame:	Compaction Chamber	3/16"
	Structure	Structural Steel Tube & Channel
Ram:	Face Plate	1/2"
	Side Plates	3/8"
Container:	Floor Plate	7 GA
	Side Plates	10 GA
	Supports	C3 x 4.1# Structural Steel Channel
	Lift Pockets	1/4" Formed Channel
Cylinders:	(2) 4" Bore x 2" Rod x 30" Stroke	
Force Rating (Ram PSI/Force in Lbs.)		
	Normal	18.2/39,200
System Pressure		
	Normal	1,600 PSI
Pump:		6 GPM
Motor:		5 HP
Oil Reservoir:		15 Gallons
Average Cycle Time:		57 Seconds
Chamber Volume:		1.57 Cubic Yards
Door Opening:		52" Wide x 30" High
Ram Penetration:		8"
Ram Face Dimensions:		59" x 36"
Safety Panels		
Removable Access Panels		
Power Unit, Self Contained		
	(Remote on 2 Cu. Yd. Container Model)	
Compaction Chamber Door Mounted on Front,		
Rear or Either Side		

Standard Features (Continued)

Safety Interlock on Chamber Door
Water Tight Container
Container Safety Interlock System
UL Listed Electrical Components
Controls Mounted on Compactor:
Keyed Start Switch
Emergency Stop Button
Container Full Light
Pull Container Light
Load-Pack Switch
Three Phase, Tri-Volt (208, 230, 460) Motor
Oil Sight Gauge w/Thermometer
Hydraulic Oil - Suitable for Wide Temperature Range

Optional Features

Security Chute (Side or Rear)
Deodorizer Spray System
UL Certified Panel
Advance Full Load Indicator
Remote Control Station
Remote Power Unit
TEFC Motor
Single Phase Motor
Low Oil Indicator w/Shutdown
Hot Oil Indicator w/Shutdown
Oil Pressure Gauge
Thermo Oil Heater



SP Industries, Inc., 2982 Jefferson Rd., Hopkins, MI 49328
Phone: 800-592-5959, In MI (269) 793-3232, Fax (269) 793-7451

Specifications and design subject to change without notice pending improvements to our equipment.

VSP-IV 09/00